

Table of Contents

This exhibitor manual is designed to help you plan for the 2010 Energy Trust Better Living Show. It contains necessary information and links to order forms to aid you in making your exhibit arrangements. It will be updated periodically, so please check back as we get closer to the show.

General Information

- Pipe & Drape
- Location
- Thursday Hall Cleaning
- Show Decorator
- Electrical Service Contractor
- Audio Visual Contractor
- Facility
- Public Relations
- Solicitation
- Recycling
- Hotel
- Transportation
- Show Management Office
- Smoking
- Concessions/Food

Show Rules & Regulations

- Exhibit Space Cancellation
- Subleasing
- Exhibit Hall admittance
- Exhibit Space Occupancy
- Aisles
- Liability
- Hanging Banners
- Handouts
- Demonstrations & Booth Activities
- Canopies / Enclosed Booths
- Helium Balloons
- Food Samples
- No alcohol Policy
- Flammable Material
- Natural Gas
- Structural Integrity
- Children & Animals
- Display Vehicles

Display Guidelines

- Exhibitor Display Guide & Policies

Move-In Information

Move-in Schedule

Tips for Move-In

Fork Lift Service

Freight Handling

Move-Out information

Move-out Schedule and Information

Decorator

Order Form

Electrician

Booth Lighting Form

Specialty Lighting Order Form

Facility

Telephone Order Form

Internet Order Form

Parking

Natural Gas Order Form

General Exhibit Information

Show Management will provide each 10' x 10' exhibit space with the following:

Pipe and Drape

8' high black drape in the back

3' high black drape on both sides

Electrical

1 -600 w electrical outlet – fourplex

One 500 w flood light per booth (house lights are out for this show)

20' x 20' and larger peninsula booths will receive an 8' H x 10' W drape with two 3' H x 5' W wings.

Island spaces do not receive pipe and drape

Exhibitor must provide their own floor covering and furnishings for their exhibit space.

Location

Portland Expo Center
Hall E
2060 N Marine Drive
Portland, Oregon 97217
503-736-5200

Loading docks and move-in doors are on the west side of the facility off of Force Avenue.

Show Dates & Hours

Friday, March 26	Noon – 9:00 pm
Saturday, March 27	11:00 am – 9:00 pm
Sunday, March 28	11:00 am – 5:00 pm

Friday Hall Cleaning

The exhibit hall will be cleaned by the facility starting at 8:00 pm on Thursday, March 25 in preparation for the show opening the next day. Please be moved in by then and have all packing material recycled or removed from the building. All exhibitors must clear the building at this time.

Official Show Decorator

DWA Trade Show & Exposition Services is the official decorator for the Energy Trust Better Living Show. Please refer to the Decorator section for more information on services.

Official Electrical Contractor

Hollywood Lights is the official show electrical services contractor. Please refer to the Electrical section for more information on services. Remember the house lights are out in this show and we will supply one arm light per booth.

Security

Show management will provide one watchman for the exhibition hall during non-show hours for fire safety. This person is not their as a guard of your property and Show Management is not liable and cannot assume responsibility for loss or damage to any products, materials or displays. It is advised to remove valuable item when you leave your booth or to store them in a safe place whenever the booth is unattended.

Solicitation

Solicitation by non-exhibitors is a disruption to those who have paid for the opportunity to market their company at the show. Please let the Show Management know immediately if you are solicited or if you observe selling by anyone other than exhibitors. You may use your cell phone and call our show office at 503-736-5216 to report solicitors.

Exhibit Space Cleaning

Show Management will maintain the aisles and other public areas within the show. Exhibitors are responsible for cleaning and maintaining their own exhibits. You may order exhibit cleaning from DWA Trade Show & Exposition Services.

Hotels

Courtyard Marriott - North Harbour

1250 N Anchor Way

Portland, OR 97217

(503)285-9888

\$85.00 plus tax (single or double occupancy, includes continental breakfast for two)

The Fairfield Inn & Suites

1250 N Anchor Way

Portland, OR 97217

(503)285-9888

\$75.00 plus tax (single or double occupancy, includes an extended continental breakfast)

Both properties have reserved a limited number of rooms at a special show rate of for the nights of Thursday March 25 through Sunday March 28. They will hold these rooms until March 5, 2010. After this date, all unreserved rooms will be released, but reservations will still be accepted on a space availability basis at the going rate.

You should identify yourself with the Better Living Show when making [reservations](#) in order to receive the special rate.

Transportation

Both hotel properties have a shuttle that will take you to the Portland Expo Center. We have arranged for a sustainable transportation option as well.

Eco Shuttle

The show shuttle departs from the hotel one hour before the show opens and returns to the hotel fifteen minutes after the show closes each day. Space is limited and you must call ahead of time to reserve a seat 503-548-4480.

Show Management Office

At the facility, Show Management will have an office located next to the loading docks on the west end of the Portland Expo Center. The phone number at that time will be 503-736-5216.

Smoking

The Portland Expo Center is a non-smoking facility.

Concessions/Food

Various food stations will be open during the show. Please support these vendors and do not bring in food from the outside.

Show Rules & Regulations

Exhibit Space Cancellation

If an exhibitor wishes to cancel their exhibit space contract, the exhibitor may only do so by giving written notice to Blue Ocean Events. Cancellation requests 60 days or more before the start of the show will forfeit 50% of the total exhibit fee. Cancellation requests 59 days or less will forfeit full payment of the exhibit fee. Please refer to [contract](#) for specifics.

Subleasing

Exhibitors are not allowed to share their space with a non-contracted company or organization. Exhibitor forfeits their right to their space if subleasing occurs and will not be allowed in future shows. Please contact show management for clarification.

Exhibit Hall Admittance

For security reasons, the hall will be cleared and locked after close of the show each day. No one will be allowed into the exhibit hall after show closing or prior to one hour before show opening. Exhibitors needing to work in their booth earlier must go to the show office the night before and get special permission and sign up on the early admittance sheet. Exhibitors are not allowed to wander the show floor and must stay in their booth prior to show opening.

Show management reserves the right to refuse entry or remove from the exhibit hall anyone deemed by Show Management not to be following the rules.

Exhibit Space Occupancy

Exhibitors must occupy their exhibit space during stated show hours. Any booth that is dismantled and/or unoccupied prior to the official closing of the show may lose the opportunity to participate in future shows.

If exhibitor has not moved into their space by 8:00 pm on Thursday, March 25, Show Management may take control of the space for purposes as they see fit without refund to the exhibitor.

Aisles

The aisles and overhead spaces remain strictly under the control of Show Management, and no signs, decorations, banners, balloons, advertising matter, or special exhibits will be permitted in the except by special written permission of Show Management. All exhibits and their personnel must remain within the confines of their space. No exhibitor will be permitted to erect signs or display products in such a manner as to obstruct the view, occasion injury, or disadvantageously affect the display of other exhibitors except with approval of Show Management.

Liability

Neither Show Management nor the Portland Expo Center shall be responsible for loss or damage occurring to the exhibits from any cause. Small and valuable exhibit materials should be removed or protected when the show is not open. Insurance must be obtained by the exhibitor. The exhibitor agrees to protect and hold harmless Show Management, Portland Expo Center and MERC against any and all claims for loss, injury or damage to persons or property arising out of the activities of the exhibitor, his agents, employees, or guest; to defend Show Management, Portland Expo Center and MERC against any and all such claims and to reimburse and indemnify Show Management, Portland Expo Center and MERC for any loss, damage, expense, or payment suffered thereby.

The exhibitor is entirely responsible for the space rented and shall not injure, mar, or deface the premises. The exhibitor shall not drive, not permit to be driven and nails, hooks, tacks, or screws in any part of the Portland Expo Center. Furthermore, the exhibitor shall not affix to the walls or windows of the facility any advertisements, signs, etc., or use scotch tape, masking tape, or any other adhesive-type materials on painted surfaces. Removable carpet tape may be purchased from the show decorator. Fines will be assessed for use of improper tape requiring labor to remove residue. Exhibitor shall not use tape, pins or staples in the drape. Automobiles, trucks and similar conveyances must have prior approval from Show Management and shall have a drip pan and/or protective material under them to protect the floors from dirt, oils stains, etc. The exhibitor agrees to reimburse Show Management and/or Portland Expo Center for any loss or damage to the premises or equipment rented to the exhibitor.

Hanging Banners

Exhibitors may hang banners in their booth as long as it stays within the height guidelines (no higher than 8'). For exhibitors in spaces that are 400 square feet or larger, an overhead sign is allowed provided it is not objectionable and there are no physical constraints in the facility to hanging the banner. Exhibitors wishing to have an overhead sign hung should notify the show decorator by February 26. Only the show decorator may hang banners or exhibit structures in the facility. A sign and banner hanging order form is [available here](#). Because the house lights are off during this show, exhibitor will need to order lighting for the banner.

Handouts

Literature, samples or other promotional materials may only be handed out within your own exhibit space. Please try to make your handouts out of materials that are recycled or recyclable and distribute them in a manner that does not create a lot of garbage.

Demonstrations & Exhibit Activities

Exhibitors shall not solicit business in aisles or engage in any activity, which leads to congestion in the aisles. Exhibitors wishing to include demonstrations, presentations, drawings, or crowd gathering activities of any type must confine such activity within their specific exhibit area.

Canopies / Enclosed Exhibits

Any enclosed structure 100 square feet or larger must have a working smoke detector properly mounted in the structure.

Helium Balloons

The display and/or distribution of helium-inflated balloons is prohibited at all times within the Portland Expo Center due to housekeeping and sprinkler systems concerns.

Food Samples

Exhibitors wishing to sample food or drink must adhere to size limitations of “bite size” for food and 2-3 ounces for liquid. Food samples should be distributed in recyclable or biodegradable containers.

No Alcohol Policy

It is show policy that exhibitors are prohibited from consuming alcohol in their exhibit spaces during show hours and at any time during move-in/move-out.

Flammable Material/Gasses

All decorative materials must be flame proofed or of a type acceptable to the Fire Marshal's Office such as table skirts. Use of hay, bark mulch, chips etc. are not allowed unless pre-approved by the Fire Marshal's Office.

No flammable gasses, liquids or solids are allowed in any building, enclosed tent or structure.

Natural Gas

All natural gas lines used to run a fireplace etc must have a shut-off valve by the appliance(s) and be accessible. All persons working in the exhibit shall be instructed in the location and operation of the shut-off valves to the appliances and to the building as well. Any exhibit with natural gas must have an approved fire extinguisher.

Natural gas lines are run by the Portland Expo Center and can be ordered [on-line](#).

Portable space heaters are not allowed unless approved by the Fire Marshal's Office.

Structural Integrity

All exhibit displays should be designed and erected in a manner that will withstand normal contact or vibration caused by neighboring exhibitors, wind, hall laborers or installation/dismantling equipment such as fork lifts.

Exhibits should be designed to fit a 10' x 10' space (that includes base plates for the pipe). Therefore, please build backwalls no wider than 9'6".

Children and Animals

For safety and liability reasons, please do not bring children or animals to the show during move-in and move-out.

Vehicles

Displaying of vehicles requires vehicles to have ¼ or less of fuel in the tank, gas cap either locked or tapes in place and battery cables taped or batteries removed.

Displaying of any vehicles containing LPG gas propane shall have tanks removed before bringing them into the building.

Cardboard Boxes

Empty cardboard boxes are not to be stored in the exhibits overnight. You may recycle your boxes outside the west end of the Portland Expo Center in the proper receptacles.

Amendment to Rules

Any and all matters or questions not specifically covered by the preceding rules and regulations shall be subject solely to the decision of Show Management. These rules and regulations may be amended at any time by Show Management. Please refer to the [rules and regulations](#) that you agreed to when you applied for space.

EXHIBITOR DISPLAY GUIDE & POLICIES

Display Restrictions

Exhibits should be designed to fit into a 10' x 10' space that includes base plates for the pipe and drape. Therefore, please build backwalls no longer than 9'6" for a 10' x 10' space. Exhibit fixtures, components and identification signs are permitted to a maximum height of 8' and may be extended a maximum of 5' out from the back wall of your display. Exhibits exceeding 8' must have approval from show management no later than 30 days prior to the show and, if allowed, backsides of the display over 8' high and exposed sidewalls over 3' high must be completely finished, i.e. painted, draped, etc.

Fixtures should not exceed 4' in heights in the front 5' of your exhibit, unless they are at least 10' from neighboring exhibits. Any portion of the exhibit bordering another booth must have the backside of that portion finished.

Exhibit display fixtures, signs, banners, etc. may not extend into the aisle.

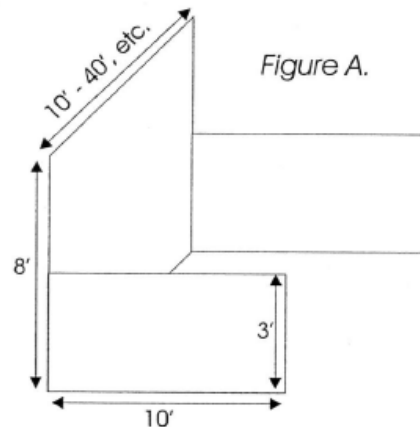

The Good Neighbor Policy:

Each exhibitor is entitled to a reasonable sight-line from the aisle, regardless of the size of the exhibit. Please be aware of your neighbors and do not design an exhibit that blocks them in.

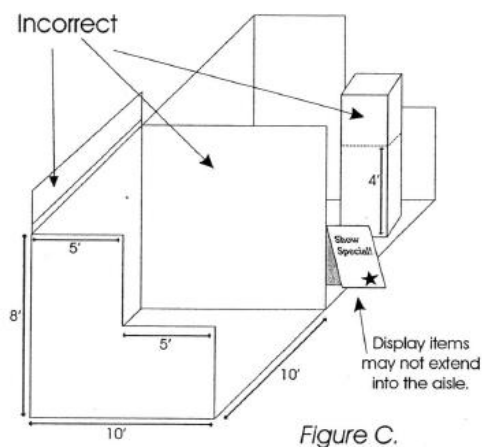
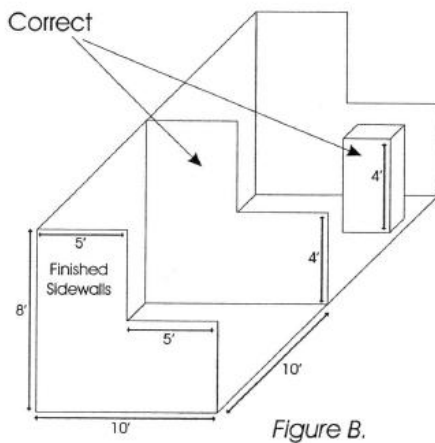

Move-In Information

Move-in is on Wednesday March 24 and Thursday March 25 from 8:00 am – 8:00 pm.

Forklift Service

Show Management provides free forklift service on a short-term limited basis only. This service is meant to assist Show Management in moving you into the facility and to eliminate vehicle congestion in the exhibit hall during move-in and move-out. For example, the free service may be used as follows:

To carry a few pallets of display items from the loading dock to your booth (10-15 minutes maximum).

The free service is not to be used for unloading truckloads of display items, moving crates to and from you booth, or positioning items in your display.

For those exhibitors with more time-intensive needs, or with displays that require special attention and handling, you must arrange for forklift service through DWA and pay either on a per hour or weight basis. Exhibitors who might typically need this type of service are those with large truckloads of items needing unloading, those with crated display products, or those who need heavy items positioned in their display. Please contact DWA to [order the forklift](#) in advance.

Freight Handling

If you are having items shipped to the show, you must contract for drayage services from DWA. They will deliver your shipment directly to your booth. If you do not contract with DWA, please be sure someone is at the facility to meet the delivery person. Show Management cannot be responsible for receiving shipments for any exhibitors at the Portland Expo Center. Please contact DWA to [order drayage services](#).

Tips for Move-In

Check in at the show office on the west end of the building next to move-in doors when you first arrive to make sure your booth number is correct.

Do not wait until the last minute to move-in. Services such as free forklift are on a first come first served basis and there may be delays.

Be patient...there are times when other exhibitors are moving in and you may be delayed. It's a team effort so prepare for it.

Driving a vehicle to your booth is at the discretion of Show Management. Vehicles allowed to drive in will have 30 minutes to unload and then will need to exit the building and park.

Move-Out Schedule & Information

No dismantling of booths until after the show has been officially closed. No removing of display items from the facility prior to show closing. No loading in of packing boxes prior to show closing. Failure to comply may result in your organization's exclusion from future shows.

After the show closes on Sunday night, the hall needs to be cleared of attendees before the freight doors will be rolled up. You will not be able to drive in until 7:00 pm Sunday night and only at the discretion of Show Management. We ask for your patience and suggest that you use this time to pack up everything in your exhibit space while staying out of the aisles. Do not park your vehicles on the loading dock nor block the driveways to the freight doors.

Schedule

Move out will be from 5:00 pm on Sunday night until 10:00 pm at which time the building will be secured. We will reopen the building at 8:00 am Monday morning and all exhibits must be totally removed from the building by Noon that same day. No exceptions.

Services

Decorator

DWA Trade Show & Exposition Services

Services: Furniture and carpet rental, set-up and dismantle labor, signs, display components, freight handling and drayage, forklift service, banner hanging.

503-228-6800 FAX 503-228-6808 – [ORDER FORMS](#)

Electrician

Hollywood Lights

Services: Electrical power for booth and specialty lighting.

503-232-9001 FAX 503-517-8686 - [ORDER FORMS](#)

Facility

Portland Expo Center

503-756-5200 – FAX 503-736-5201 - [ORDER FORMS](#)

Services: Phones, internet service, gas lines, parking

Parking

You may buy a parking pass for \$21.00 with in and out privileges from the Portland Expo Center during move-in.